

Fundamentals of stepper motor drive technology

FESTO

Workbook
TP 1422



With CD-ROM

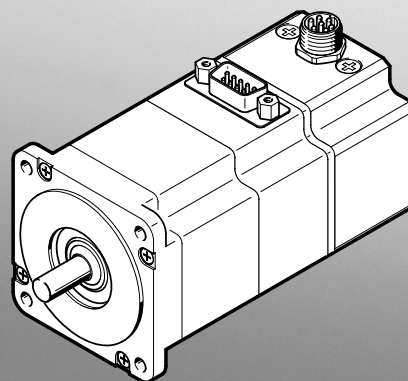
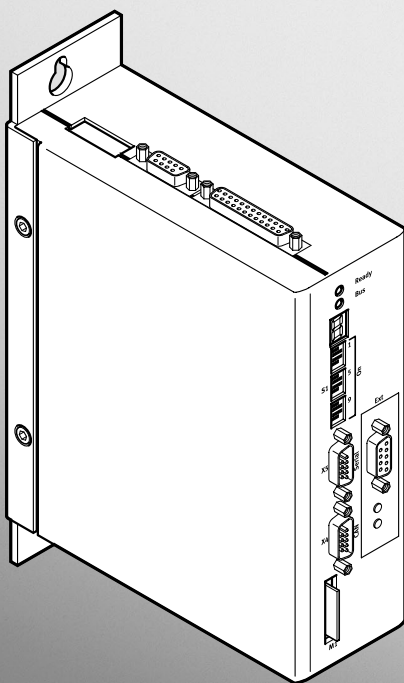

Order No.: 571861
Edition: 04/2010
Authors: Frank Ebel, Markus Pany
Graphics: Markus Pany
Layout: 12/2010, Susanne Durz, Frank Ebel

© Festo Didactic GmbH & Co. KG, 73770 Denkendorf, Germany, 2010
Internet: www.festo-didactic.com
E-mail: did@de.festo.com

The copying, distribution and utilization of this document as well as the communication of its contents to others without expressed authorization is prohibited. Offenders will be held liable for the payment of damages. All rights reserved, in particular the right to carry out patent, utility model or ornamental design registration.

Contents

Use for intended purpose	IV
Preface	V
Introduction	VII
Work and safety instructions	VIII
Training package for the basic principles of stepper motor drive technology (TP 1422)	IX
Learning objectives	X
Allocation of learning objectives and exercises	XI
Equipment set for Basic Principles of Stepper Motor Drive Technology (TP 1422)	XII
Allocation of components and exercises	XII
Notes for the teacher/trainer	XIII
Structure of the exercises	XIV
CD-ROM contents	XV

Exercises and solutions

Exercise 1: Design of a stepper motor system	1
Exercise 2: Configuring and commissioning a stepper motor system	7
Exercise 3: Speed control of a stepper motor system	19
Exercise 4: Homing and positioning in a stepper motor system	43
Exercise 5: Positioning mode and sequence control	57
Exercise 6: Travel program with record linking	73

Use for intended purpose

The training package for Basic Principles of Stepper Motor Drive Technology may only be used:

- For its intended purpose in teaching and training applications
- When its safety functions are in flawless condition

The components included in the training package are laid out in accordance with the latest technology as well as recognised safety rules. However, life and limb of the user and third parties may be endangered, and the components may be impaired, if they are used incorrectly.

The learning system from Festo Didactic has been developed and manufactured exclusively for training and vocational education in the field of automation and technology. The respective training companies and/or trainers must ensure that all trainees observe the safety precautions which are described in this workbook.

Festo Didactic hereby excludes any and all liability for damages suffered by trainees, the training company and/or any third parties, which occur during use of the equipment sets in situations which serve any purpose other than training and/or vocational education, unless such damages have been caused by Festo Didactic due to malicious intent or gross negligence.

Preface

Festo Didactic's learning system for automation and technology is geared towards various educational backgrounds and vocational requirements. The learning system is therefore broken down as follows:

- Technology-oriented training packages
- Mechatronics and factory automation
- Process automation and control technology
- Robotino® – training and research with mobile robots
- Hybrid learning factories

The technology packages deal with various technologies including pneumatics, electropneumatics, hydraulics, electrohydraulics, proportional hydraulics, programmable logic controllers, sensor technology, electrical engineering and electric drives.

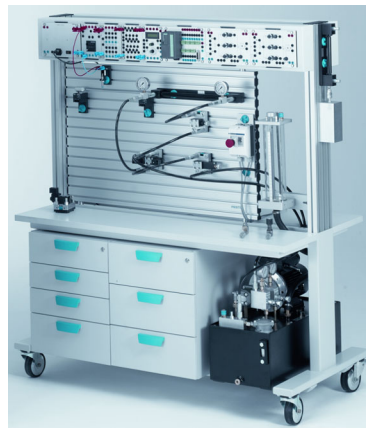

The modular design of the learning system allows for applications which go above and beyond the limitations of the individual packages. For example, PLC actuation of pneumatic, hydraulic and electric drives is possible.

All training packages have the same structure:

- Hardware
- Teachware
- Software
- Seminars

The hardware is comprised of industrial components and systems that are specially designed for training purposes.

The structure of the teachware corresponds to that of the training hardware. It includes:

- Textbooks (with exercises and examples)
- Workbooks (with practical exercises, supplementary instructions and solutions)
- Exercise books (with practical exercises and supplementary explanations)
- Transparencies and videos (for dynamic instruction)

The teaching and learning media are available in several languages. They're intended for use in classroom instruction, but are also suitable for self-study.

Where software is concerned, computer training programs, as well as simulation, visualisation, project engineering, design engineering and programming software, are made available.

A wide range of seminar offerings covering the contents of the training packages round off the programme for training and vocational education.

If you have any suggestions or feedback about this manual,

please send us an e-mail at: did@de.festo.com

The authors and Festo Didactic look forward to your comments.

Introduction

This workbook is part of the learning system for automation and technology by Festo Didactic GmbH & Co. KG. The system provides a solid basis for practice-oriented basic and further training. The training package TP 1422 deals with the subject of Basic Principles of Stepper Motor Drive Technology.

Special emphasis is placed on the setup, function, connection, range of applications and control of a stepper motor system on the basis of the requirements for the respective application.

A permanent workstation equipped with a Festo Didactic slotted profile plate and a short-circuit-proof power supply unit with an output voltage of 24 V DC are prerequisites for setting up the components.

The circuits for exercises 1 to 5 are set up using the TP 1422 equipment set. For exercise 6, you also need an I/O simulation box and an I/O SysLink cable. These two components are not included in the equipment set.

Technical data for the individual components are also available (sensors, drives, motor controllers, etc.).

Work and safety instructions



General

- Trainees should only work with the circuits under the supervision of a trainer.
- Observe the specifications included in the technical data for the individual components and in particular all safety instructions!
- Faults which may impair safety must not be generated in the training environment and must be eliminated immediately.

Mechanical setup

- Mount all the components securely onto the slotted profile plate.
- Observe the instructions regarding positioning of the components.

Electrical setup

- Only use extra low voltages, maximum of 24 V DC.
- Establish or interrupt electrical connections only in the absence of voltage!
- Only use connecting cables with safety plugs for electrical connections.
- Only pull the safety plugs when disconnecting connecting cables – never pull the cable.

Mounting technology

The mounting boards for the components are equipped with mounting variants A, B or C:

- Variant A, snap-in system
Lightweight components that are not subject to loads (e.g. directional control valves, sensors). Simply clip the components into the slots on the slotted profile plate. Release the components by actuating the blue lever.
- Variant B, bolt
Components subject to medium loads (e.g. pneumatic cylinders). These components are clamped onto the slotted profile plate using T-head bolts. The blue, knurled nut is used for clamping and releasing.
- Variant C, screw system
For components that will be subject to heavy loads and components that are rarely removed from the slotted profile plate (e.g. on-off valve with filter regulator). The components are fastened using socket head screws and T-head nuts.

Training package for "Basic Principles of Stepper Motor Drive Technology" (TP 1422)

The training package TP 1422 consists of a multitude of individual training materials. The subject of this package is stepper motors. Individual components included in the training package TP 1422 can also be included in other packages.

Important components of TP 1422

- Permanent workstation with Festo Didactic slotted profile plate
- Equipment sets or individual components (e.g. sensors, motors, motor controllers)

Media

The teachware for the training package TP 1422 consists of a workbook. The workbook contains the worksheets for each of the 6 exercises, the solutions for each individual worksheet and a CD-ROM. A set of ready-to-use exercise sheets and worksheets is included for each exercise.

Technical data for the hardware components is made available along with the training package and on the CD-ROM.

The Festo Configuration Tool (FCT) software is also made available for the training package TP 1422. This can be used to configure the required functions for the electric drives. The drive function is implemented through the controller-motor-axis function chain. The software adjusts these components to each other.

You'll find further training materials in our catalogue and on the Internet. The learning system for automation and technology is continuously updated and expanded. Transparency sets, videos, CD-ROMs, DVDs and training programs as well as additional teachware are offered in several languages.

Learning objectives

■ Stepper motors

- Become familiar with the safe design or mounting of a stepper motor system.
- Become familiar with the basic principles of connection technology and circuit technology of the components used.
- Become familiar with the safe and correct commissioning of a stepper motor system.
- Become familiar with the basic principles of configuration and parameterisation of a stepper motor system using the Festo Configuration Tool (FCT).
- Be able to set and regulate the speed of a stepper motor system.
- Be familiar with the options for setting different acceleration and braking deceleration speeds using FCT.
- Become familiar with the basic principles of configuration and recording of measurement data using FCT.
- Be able to carry out homing in a stepper motor system.
- Be able to set positions and position records and select positions.
- Be able to control the positioning procedures in a stepper motor system using sequence control.
- Be able to check position records using FCT in a test cycle.
- Become familiar with the various operating modes of a motor controller.
- Be able to create and control a directional program with position record linking.
- Be able to teach in positions.

Allocation of learning objectives and exercises

Exercise	1	2	3	4	5	6
Learning objectives						
Become familiar with the safe design or mounting of a stepper motor system	•					
Become familiar with the basic principles of connection technology and circuit technology of the components used	•					
Become familiar with the safe and correct commissioning of a stepper motor system		•				
Become familiar with the basic principles of configuration and parameterisation of a stepper motor system using the Festo Configuration Tool (FCT).		•				
Be able to set and regulate the speed of a stepper motor system			•			
Become familiar with the options for setting different acceleration and braking deceleration speeds using FCT			•			
Become familiar with the basic principles of configuration and recording of measurement data using FCT			•			
Be able to carry out homing in a stepper motor system				•		
Be able to set positions and position records and select positions				•		
Be able to control the positioning procedures in a stepper motor system using sequence control					•	
Be able to check position records using FCT in a test cycle					•	
Become familiar with the various operating modes of a motor controller						•
Be able to create and control a directional program with position record linking.						•
Be able to teach in positions.						•

Note

For exercise 6, you also need an I/O simulation box and an I/O SysLink cable. These two components are not included in the equipment set.

Equipment set for Basic Principles of Stepper Motor Drive Technology (TP 1422)

The equipment set for Basic Principles of Stepper Motor Drive Technology (TP 1422) teaches students about the basic principles and use of stepper motors. It contains all the components needed to work through the specified learning objectives and can be supplemented with other equipment sets.

To create operational circuits, the slotted assembly board and a 24 V DC power supply unit are also necessary.

Component	Order no.	Quantity
Stepper motor controller CMMS-ST-... (incl. interface cable)		1
Stepper motor EMMS-ST-57-... (incl. connecting cables)		1
Rotary drive		1
Inductive proximity sensor M8		2
Connecting cable sensor		2
Festo Configuration Tool software		1

To carry out exercise 6, you will also need the following components.

Component	Order no.	Quantity
I/O simulation box		1
I/O SysLink cable		1

Allocation of components and exercises

Component	Exercise	1	2	3	4	5	6
Stepper motor controller CMMS-ST-...		1	1	1	1	1	1
Stepper motor EMMS-ST-57-...		1	1	1	1	1	1
Rotary drive		1	1	1	1	1	1
Inductive proximity sensor M8		2	2	2	2	2	2
Connecting cable sensor		2	2	2	2	2	2
Festo Configuration Tool software			1	1	1	1	1
I/O simulation box							1
I/O SysLink cable							1
24 V DC power supply unit		1	1	1	1	1	1

Notes for the teacher/trainer

Learning objectives

The basic learning objective of this workbook is to become familiar with stepper motors and with the assembly of a stepper motor system. The combination of both theory and practice ensures faster progress and longer-lasting learning. The more specific learning objectives aims are documented in the matrix. Concrete, individual learning objectives are assigned to each exercise.

Required time

The time required for working through the exercises depends on the learner's previous knowledge of the subject matter. For apprentices in the field of metal working or electrical engineering this is approx. 1 week. For a skilled worker it is approx. 2 days.

Equipment set components

The workbook and the equipment set match each other. For exercises 1 to 5, you only need the components included in the equipment set TP 1422. For exercise 6, you also need an I/O simulation box and an I/O SysLink cable. These two components are not included in the equipment set.

Each exercise can be realised using a slotted mounting frame or slotted profile plate with a width of at least 350 mm.

Designations in the solution sheets

Solutions and supplements in graphics or diagrams are in red.

Designations in the worksheets

Texts which require completion are identified with a grid or grey table cells.
Graphics which require completion include a grid.

Solutions

The solutions specified in this workbook are the results of test measurements. The results of your measurements can deviate from these data.

Learning topics

The table below contains an overview of the learning topics offered by educational institutions for selected professions on the subject matter of "Basic Principles of Stepper Motor Drive Technology".

Vocation	Learning topic	Subject
Electronics engineer for automation technology	1	Analysing electrical systems and testing their functions
	3	Analysing and adapting controllers
	6	Analysing systems and checking their safety
Mechatronics technician	3	Installation of electric equipment, taking into account technical safety aspects
	4	Examination of the flow of energy and information in electrical, pneumatic and hydraulic modules
	7	Implementing mechatronic subsystems
	11	Commissioning, troubleshooting and repair
Industrial mechanic	10	Installing and commissioning technical systems

Structure of the exercises

All 6 exercises have the same structure and are broken down into:

- Title
- Learning objectives
- Problem description
- Positional sketch
- Project assignment
- Work aids
- Worksheets

CD-ROM contents

The workbook is included on the CD-ROM as a PDF file. The CD-ROM also provides you with additional media.

The CD-ROM contains the following folders:

- Operating instructions
- Technical data
- Product information
- Software tools

Operating instructions

Operating instructions for various components in the training package are available. These instructions are helpful when using and commissioning the components.

Technical data

The technical data for the components included in the training package is available as PDF files.

Product information

The manufacturer's product information is provided for selected components. The representations and descriptions of the components in this format are intended to demonstrate how they are presented in an industrial catalogue. Additional information regarding the components is also included.

Software tools

The software tools to work on the exercises are provided on the CD-ROM.

Note

Up-to-date information and additional software tools please find at the address:
www.festo.com › Support and Downloads › Software › Electrical drives.

Exercise 1

Constructing a stepper motor system

■ Learning objectives

After completing this exercise:

- You will be familiar with the safe design or assembly of a stepper motor system
- You will be familiar with the basic principles of connection technology and circuit technology of the components used

■ Problem description

A stepper motor system is to be constructed using individual components. To do this, the motor controller, stepper motor, rotary drive, signal input and proximity sensor must be correctly connected or linked in order to obtain a reliable, complete system.

■ Positional sketch

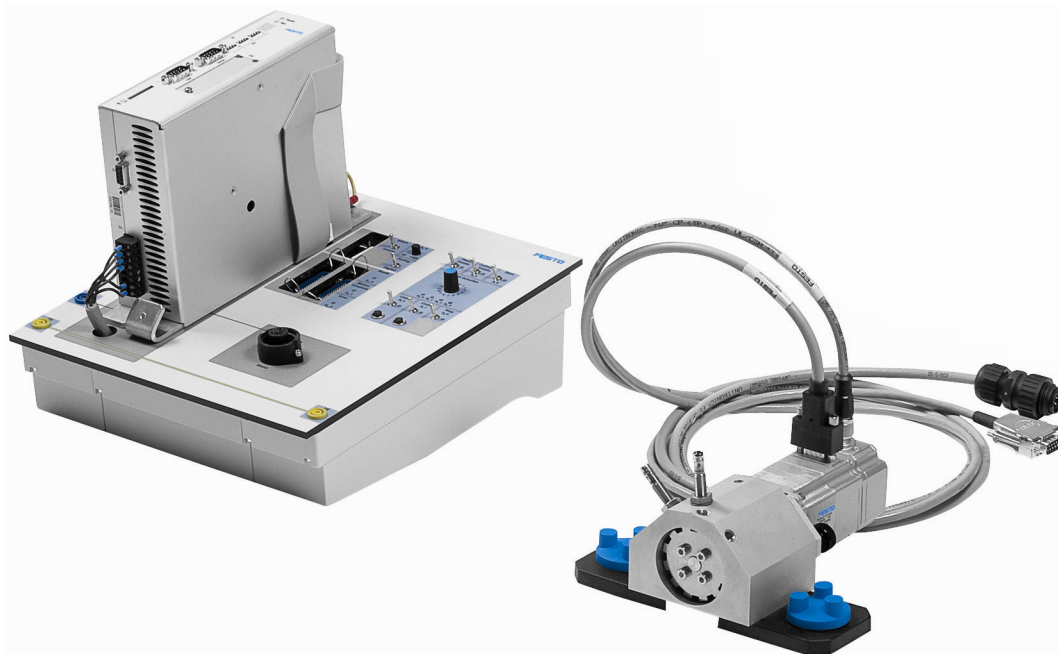

Stepper motor system

■ **Project assignment**

1. Describe the design and function of the components used.
2. Connect the modules to form a complete, reliable system.

■ **Work aids**

- Technical data
- Operating instructions



Warning

The electric power supply must not be switched on until all connections have been made and checked. The power supply must be switched off again once the exercise has been completed and before the components are removed.

■ Function description

- Complete the following table. Use the required data from the data sheet for the inductive proximity sensor.

Parameters	Value
Working range/rated operating distance	1.5 mm
Repetition accuracy	0.07 mm
Operating voltage	10 – 30 V DC
Switching output	N.C., normally closed
Switching frequency	5000 Hz

- Complete the following table. Use the required data from the data sheet for the stepper motor.

Parameters	Value
Operating voltage	48 V DC
Nominal current	5 A
Holding torque	0.8 Nm
Stepper angle	1,8 ° ±5%
Mass moment of inertia of rotor	0.29 kgcm ²

- Complete the following table. Use the required data from the data sheet for the motor controller.

Parameters	Value
Supply voltage load [X9]	48 V DC
Nominal current control section [X9]	0.2 A
Output current [X6]	8 A _{eff}
Number of digital switching outputs [X1]	4
Signal level of analogue inputs [X1]	-10 – +10 V

■ Construction of the complete system

1. Connect the motor
 - Make sure that the power supply is switched off.
 - 24 V power supply unit is switched off
 - Fasten the motor to the rotary drive using the locking screws and mount the module onto the slotted profile plate.
 - Connect the motor cable to the controller unit.
 - Plug the motor cable into the socket [X6] of the controller unit and tighten it.
 - Mount the proximity sensors in the sensor retainer of the rotary drive.
 - Connect the proximity sensors via sensor cables to the controller unit (D_{in}6-Limit0/D_{in}7-Limit1).

Note

End-position sensing can take place with sensors or using signal switches.

2. Connect the motor controller
 - Connect the controller unit to the 24 V power supply unit using 4 mm safety plug connectors.
3. Connect the PC
 - Connect the controller unit to the PC with the serial interface cable.
 - Insert the sub-D plug connector of the serial cable into socket [X5] RS232/COM of the motor controller
 - Tighten the locking screws.
4. Check readiness for operation
 - Make sure that the "Controller Enable" switch is switched off.
 - Check all plug connectors once again.
 - Switch on the power supply of the equipment. The READY LED on the front of the motor controller should now light up.
5. Switch off system and power supply
 - Switch "Power Enable", "Controller Enable", "Stop", "Start" into the position AUS/OFF (switch upwards).

- Check the switches of the signal input.
 - Signal switches "Limit0" and "Limit1" are in position OFF/AUS (switch upwards)
 - Potentiometer switch A_{in0} is in position 0
 - "Record Selection" selector switch is in position 0
 - "Analogue/Digital" selector switch is in digital position (switch downwards)
 - "Internal/External" selector switch is in internal position (switch upwards)•
- Switch off the 24 V DC power supply unit.

Note

Through the sub-D socket [X1], external analogue signals can be recorded or output by the controller. Analogue setpoint specification by hand is done using the potentiometer switch A_{in0} . Make sure that the "Internal/External" selector switch is in the "Internal" position (switch upwards)!

If the READY LED is not lit, there is a malfunction. If the segment display shows a number sequence, there is an error message. You must rectify the cause of the message. In this case, read the operating mode and error messages in chapter 8.2 in the manual "Motor Controller CMMS-ST-...".

